



Technische Informationen

- Material muss angefast sein
- Bei dünnwandigen Spannhülsen keine Gewährleistung möglich
- Tatsächlicher Material-Ø darf nicht größer als das Nennmaß der Spannhülse sein
- Bitte beachten: Material kann an den Enden oval vom Abschlagen sein und daher dort größer als in der Mitte. Prüfen daher immer direkt nach der Fase, nicht in der Mitte der Materialstange
- Auf Wunsch (Mehrkosten) auch ein Messprotokoll der Spannkräfte mitlieferbar.
- Querstifte für Spannhülsen u. -adapter s. S. 26

Technical Information

- *Material has to be chamfered*
- *No warranty for thin-walled collets*
- *Diameter of material must not be bigger than the nominal size of collets*
- *Attention: Material could be bigger at the end of the bar. Do not measure in the middle of the bar, only after the chamfering*
- *Measurement report of the clamping force for extra charge*
- *Cross pins for bar feed collets and adapters see page 26*

Bar Feed Collets

Spannhülsen für Lademagazine
FMB, IEMCA, LNS, TRAUB, TORNOS

Bar Feed Collets for Bar Feeders
FMB, IEMCA, LNS, TRAUB, TORNOS

mit Gewinde
with thread



Bild 1

mit Querstiftbefestigung
pinned type



Bild 2

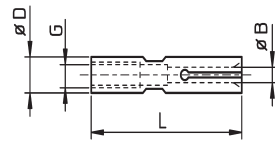

Bestell-Nr. order-no.	D	E-Nummer E-number	Bild picture	G / d	A	L	B von from	B bis to
D05	5	200E	1	M4	-	37	1,0	4,5
D07	7	208E	1	M5	-	37	1,0	5,7
D07*	7	208E	1	M5	-	37	5,8	6,7
D10	10	210E	2	7	4	40	1,0	8,9
D10*	10	210E	2	7	4	40	8,9	10,0
D11	11		2	7	4	40	8,2	9,5
D12	12	212E	2	8	4	40	1,0	10,1
D12*	12	212E	2	8	4	40	10,2	12,0
D13	13		2	8	4	40	3,0	12,0
D14	14		2	8	4	40	10,0	12,0
D15	15	203E	2	11	6	40	1,5	13,4
D15*	15	203E	2	11	6	40	13,5	15,5
D16	16		2	11	6	40	4,0	13,9
D16*	16		2	11	6	40	14,0	15,0
D18	18	218E	2	11	6	40	3,0	16,5
D18*	18	218E	2	11	6	40	16,6	17,0
D20	20	225E	2	14	8	65	2,0	17,9
D20*	20	225E	2	14	8	65	18,0	20,0
D21	21		2	14	8	65	18,0	19,5
D22	22		2	14	8	65	3,0	20,4
D22*	22		2	14	8	65	20,5	21,0
D23	23		2	14	8	65	19,0	20,0
D24	24		2	14	8	65	16,0	22,0
D25	25	222E	2	20	8	65	2,0	23,0
D25*	25	222E	2	20	8	65	23,1	25,0
D26	26		2	20	8	65	23,0	24,0
D28	28	227E	2	20	8	65	6,0	26,5
D28*	28	227E	2	20	8	65	26,6	27,0
D30	30		2	20	8	65	4,0	28,0
D32	32		2	20	8	65	3,0	30,5
D32*	32		2	20	8	65	30,6	31,0
D34	34		2	20	8	65	25,0	32,0
D36	36		2	20	8	65	4,0	34,0
D42	42		2	20	8	70	10,0	39,0
D52	52		2	20	8	70	8,0	49,0

* Außendurchmesser erweitert
Dünnwandige Spannhülsen auch als "Longlife" lieferbar
Zollmaße bis 1/16"-stg. ohne Aufpreis
Weitere Abmessungen auf Anfrage

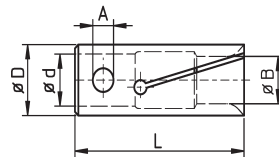
* External diameter extended
Thin-walled bar feeder collets also available in "Longlife"-type
Inch sizes up to 1/16"-step without extra charge
Other dimensions on request

12 Spannhülsen

Bar feed Collets

Spannhülsen für Lademagazine
BECHLER, LNS, TRAUB, TORNOS

Bar Feed Collets for Bar Feeders
BECHLER, LNS, TRAUB, TORNOS



Bild 1



Bild 2

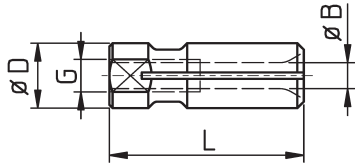

Bild 3

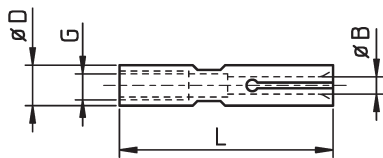

Bestell-Nr. order-no.	D	Bild picture	G	L	B von from	B bis to
D07-B	7	1	M4	22	1,0	6,0
D10-B	10	1	M5	26	2,0	8,5
DLNS06	6	2	M4	30	0,6	5,0
DLNS06L	6	3	M4	30	5,0	5,0
DLNS07	7	2	M4	30	1,0	5,5
DLNS07L	7	3	M4	30	5,0	6,0
DLNS10	10	2	M5	30	1,5	9,0
DLNS10L	10	3	M5	30	8,5	9,0
DLNS12	12	2	M6	30	3,0	10,5
DLNS12L	12	3	M6	30	10,0	11,0
DLNS125	12,5	2	M6	30	8,0	11,0
DLNS125L	12,5	3	M6	30	11,0	11,5

Vorteile von "Longlife" - Spannhülsen

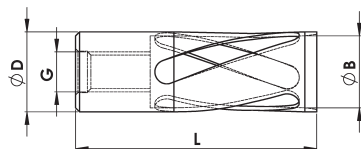
Advantages of "Longlife" bar feed collets

Beispiele:
examples:

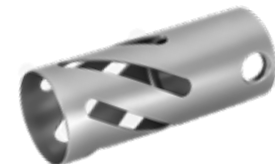
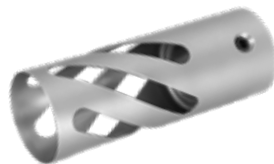

- Maximale Nutzung des Kanaldurchmessers
- Die geschlossene Form verhindert Spannkraftverlust bei hohen Drehzahlen
- Bei Ausführung "L" kann auch 4 / 6 - kt. Material verwendet werden (Ausf. "LS" nicht für 4 / 6 - Kt. Material geeignet)
- Hohe Bruchfestigkeit und Spannkraft bei dünnen Wandstärken

- Maximum use of the channel diameter
- Closed form prevents tension loss during high rotation speed
- Type "L" also suitable for square / hex material
- High breaking resistance and clamping force

Bar Feed Collets

Spannhülsen "Longlife"
FMB, IEMCA, LNS, TRAUB, TORNOS

Bar Feed Collets "Longlife"
FMB, IEMCA, LNS, TRAUB, TORNOS

Maximale Nutzung des Kanaldurchmessers
Maximum use of the channel diameter

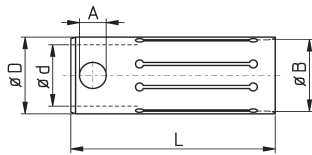
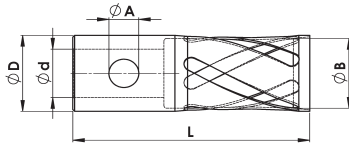

Ausführung **L**
Type

Ausführung **LS**
Type



Bestell-Nr. - order-no. Ausführung - type L	D	Bild picture	G / d	A	L	B von from	B bis to	6-kt hex
D05L	5	1	M4	--	37	3,5	4,3	
D07L	7	1	M5	--	37	4,3	6,0	
D075L	7,5	1	M5	--	37	6,0	7,0	
D10L	D10LS	2	7	4	40	6,0	9,0	6 - 8
D10L*	D10LS	2	7	4	40	9,1	9,7	8
D11L	D11LS	2	7	4	40	9,0	10,0	8
D12L	D12LS	2	8	4	40	8,0	11,0	7 - 9
D13L	D13LS	2	8	4	40	10,0	12,0	10
D14L	D14LS	2	8	4	40	11,0	13,0	12
D15L	D15LS	2	11	6	40	10,0	14,25	9 - 12
D16L	D16LS	2	11	6	40	12,6	15,1	11-13
D17L	D17LS	2	11	6	40	14,0	16,0	13
D18L	D18LS	2	11	6	40	12,0	17,0	11 - 14
D19L	D19LS	2	11	6	40	17,0	18,0	15
D20L	D20LS	2	14	8	65	10,8	19,05	13 - 16
D21L	D21LS	2	14	8	65	18,0	20,0	16 - 17
D22L	D22LS	2	14	8	65	15,5	21,0	15 - 18
D23L	D23LS	2	14	8	65	18,0	22,0	16 - 19
D24L	D24LS	2	14	8	65	20,0	23,0	18 - 20
D25L	D25LS	2	20	8	65	16,0	24,1	14 - 21
D26L	D26LS	2	20	8	65	23,0	25,0	20 - 21
D27L	D27LS	2	20	8	65	24,0	26,0	21 - 22
D28L	D28LS	2	20	8	65	20,0	27,0	18 - 23
D30L	D30LS	2	20	8	65	22,0	29,0	20 - 25
D31L	D31LS	2	20	8	65	29,5	30,0	26
D32L	D32LS	2	20	8	65	24,0	31,0	18 - 27
D33L	D33LS	2	20	8	65	30,0	32,0	27
D34L	D34LS	2	20	8	65	28,0	33,0	25 - 28
D36L	D36LS	2	20	8	65	30,0	35,0	27 - 30
D39L	D39LS	2	20	8	65	36,0	38,0	32 - 33
D42L	D42LS	2	20	8	70	39,0	41,0	34 - 35
D52L	D52LS	2	20	8	70	47,5	51,0	41 - 43

* Außendurchmesser erweitert
Zollmaße bis 1/16"-stg. ohne Aufpreis
Material muss angefasst sein
darf Nennmaß nicht überschreiten

* External diameter extended
Inch sizes up to 1/16"-step without extra charge
Bars need chamfering to prevent breakage
Do not clamp over nominal size of the collet

14 Spannhülsen

Bar feed Collets

Spannhülsen für Turbo-Lademagazine
FMB, BREUNING IRCO, LNS, TORNOS

Bar Feed Collets for Turbo Bar Feeders
FMB, BREUNING IRCO, LNS, TORNOS

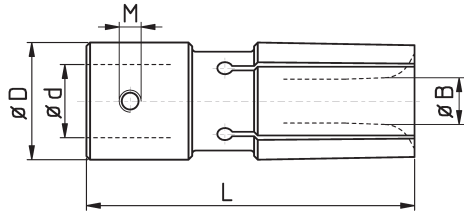

Bestell-Nr. order-no.	D	E-Nummer E-number	d	L	M	B von from	B bis to
TD25	25	2292E	20	90	M5	3,0	23,7
TD25*	25	2292E	20	90	M5	23,8	24,0
TD28	28		20	90	M5	6,0	26,0
TD30	30	2402E	20	90	M6	3,0	28,4
TD30*	30	2402E	20	90	M6	28,5	29,0
TD32	32	2422E	20	90	M6	2,5	30,5
TD32*	32	2422E	20	90	M6	30,6	31,0
TD33	33		20	90	M6	30,0	31,0
TD34	34		20	90	M6	13,0	32,0
TD36	36	2490E	20	90	M8	6,0	34,5
TD36*	36	2490E	20	90	M8	34,6	35,0
TD38	38	2517E	20	90	M8	10,0	36,0
TD40	40	2565E	20	90	M8	8,0	38,0
TD42	42	2578E	20	90	M8	5,0	40,0
TD44	44		20	90	M8	30,0	42,0
TD45	45	2610E	20	90	M8	13,0	43,0
TD50	50	2670E	20	90	M8	8,0	48,0
TD54	54	2704E	20	90	M8	33,0	51,0
TD55	55		20	90	M8	33,0	52,0
TD58	58		20	90	M8	20,0	55,0
TD60	60	2770E	20	90	M8	10,0	58,0
TD63	63	2780E	20	90	M8	28,5	60
TD65	65	2790E	20	90	M8	8,0	62,0
TD70	70		20	90	M8	50,0	66,0
TD73	73	2857E	20/35	90	M8	50,0	70,0
TD75	75	2860E	20/35	90	M8	50,0	72,0
TD80	80		35	90	M8	50,0	77,0
TD90	90	2912E	35	90	M8	50,0	86,0
TD100	100		35	110	M8	60,0	95,0

* Außendurchmesser erweitert

* External diameter extended

Zollmaße bis 1/16"-stg. ohne Aufpreis
alle Spannhülsen auch als XT-Ausführung (definierte Spannkraft) lieferbar

Inch sizes up to 1/16"-step without extra charge
All bar feed collets also available in XT-type (defined clamping force)

Für viele TD-Spannhülsen sind auch Federn zur Erhöhung der
Spannkraft lieferbar

To increase the clamping force, springs for many of
the collets are available



Bar Feed Collets

Spannhülsen "Longlife"
für Turbo-Lademagazine
FMB, BREUNING IRCO, LNS, TORNOS

Bar Feed Collets "Longlife"
for Turbo Bar Feeders
FMB, BREUNING IRCO, LNS, TORNOS

Maximale Nutzung des Kanaldurchmessers
Maximum use of the channel diameter

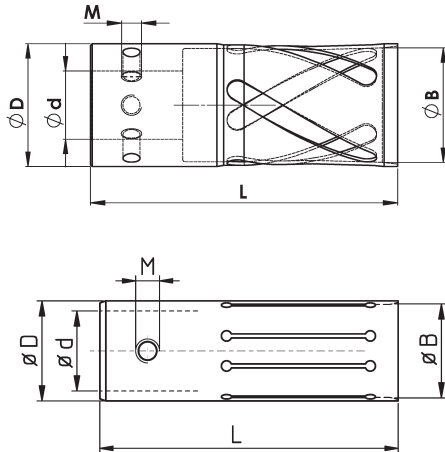

Ausführung **L**
Type

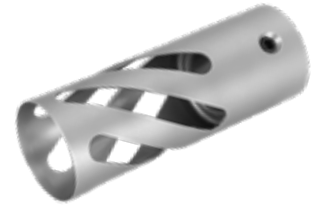

Ausführung **LS**
Type



Vorteile der "Longlife"-Spannhülsen s. S. 12 - Advantages of "Longlife" bar feed collets see page 12

Bestell-Nr. - order-no. Ausführung - type		D	d	L	B von from	B bis to	6-kt hex
L	LS						
TD25L	TD25LS	25	20	90	14,85	24,0	13 - 20
TD30L	TD30LS	30	20	90	20,0	29,0	18 - 25
TD32L	TD32LS	32	20	90	21,5	31,0	19 - 27
TD33L	TD33LS	33	20	90	30,0	32,0	26 - 27
TD34L	TD34LS	34	20	90	28,0	33,0	22 - 28
TD36L	TD36LS	36	20	90	29,0	35,0	25 - 30
TD38L	TD38LS	38	20	90	33,0	37,0	27 - 32
TD40L	TD40LS	40	20	90	38,0	39,0	31 - 33
TD42L	TD42LS	42	20	90	30,0	41,0	27 - 35
TD43L	TD43LS	43	20	90	42,0	42,0	36
TD44L	TD44LS	44	20	90	38,0	43,0	35 - 37
TD45L	TD45LS	45	20	90	40,0	44,0	35 - 38
TD50L	TD50LS	50	20	90	40,0	49,0	35 - 42
TD54L	TD54LS	54	20	90	51,0	53,0	
TD55L	TD55LS	55	20	90	45,0	54,0	40 - 46
TD60L	TD60LS	60	20	90	50,0	59,0	44 - 51
TD63L	TD63LS	63	20	90	60,0	62,0	44 - 53
TD65L	TD65LS	65	20	90	52,7	64,0	46 - 55
TD70L	TD70LS	70	20	90	65,0	68,5	
TD73L	TD73LS	73	20/35	90	68,0	71,5	
TD75L	TD75LS	75	20/35	90	70,0	73,5	
TD80L	TD80LS	80	35	90	75,0	78,0	
TD90L	TD90LS	90	35	90	85,0	87,5	
TD100L	TD100LS	100	35	110	94,0	97,5	

Zollmaße bis 1/16"-stg. ohne Aufpreis
Material muss angefast sein und
darf Nennmaß nicht überschreiten

*Inch sizes up to 1/16"-step without extra charge
Bars need chamfering to prevent breakage
Do not clamp over nominal size of the collet*

16 Spannhülsen

Bar feed Collets

Spannhülsen für Lademagazine
IEMCA, EDGE mit Aufschraubgewinde

Bar Feed Collets for Bar Feeders
IEMCA, EDGE with Right Hand Thread



Bild 1



Bild 2

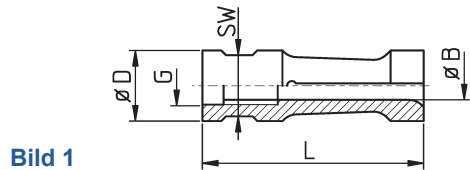

Bestell-Nr. order-no.	D	E-Nummer E-number	Bild picture	G	L	SW	B von from	B bis to
DI07	7,5	2001E	1	M5x0,5	40	6	1,4	6,35
DI07*	7,5	2001E	1	M5x0,5	40	6	6,4	6,7
DI10	10	2045E	1	M6x0,75	40	8	1,5	9,0
DI12	12	2061E	1	M7x0,75	42	10	1,6	10,3
DI15	15	2101E	1	M8x1	42	13	3,0	13,0
DI16	16		1	M8x1	42	14	10,0	14,25
DI18	18		1	M8x1	42	15	11,0	16,5
DI20	20	2197E	1	M10x1	59	17	2,5	18,5
DI20*	20	2197E	1	M10x1	59	17	18,6	19,0
DI23	23		1	M10x1	59	19	11,0	21,0
DI25	25	2289E	1	M10x1	59	22	6,0	23,0
DI27	27	2316E	1	M10x1	59	24	15,87	25,4
DI30	30		1	M10x1 **	65	27	6,0	28,0
DI31 ***	31		1	M10x1 **	65	27	8,0	29,0
DI32	32		1	M10x1 **	65	30	6,0	30,0
DI33	33		1	M10x1 **	65	30	25,0	32,0
DI34	34		1	M25x1,5	65	32	5,0	32,0
DI35	35		1	M25x1,5	65	32	15,0	33,0
DI36	36		2	M25x1,5	65	34	20,0	34,0
DI40	40		2	M25x1,5	70	36	10,0	37,0
DI42	42		2	M25x1,5	70	36	16,0	40,0
DI45	45		2	M25x1,5	72	41	20,0	42,0
DI46	46		2	M25x1,5	72	40	22,0	44,0
DI50	50		2	M25x1,5	80	46	40,0	48,0
DI52	52		2	M25x1,5	80	46	40,0	49,0
DI55	55		2	M25x1,5	80	50	34,0	52,0
DI56	56		2	M25x1,5	80	50	50,0	53,0
DI58	58		2	M25x1,5	80	50	50,0	54,0
DI60	60		2	M25x1,5	80	55	39,0	57,0
DI65	65		2	M25x1,5	80	60	50,0	62,0
DI70	70		2	M25x1,5	80	65	60,0	66,0
DI75	75		2	M25x1,5	80	65	67,0	70,0
DI80	80		2	M25x1,5	80	Querbohrung cross hole	65,0	75,0

* Außendurchmesser erweitert

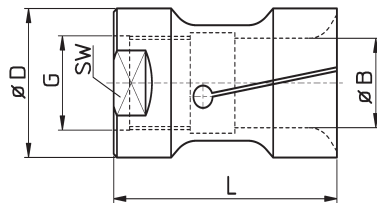
* External diameter extended

** Auch mit folgenden Gewinden lieferbar:

** Also available with threads: M17x1 ; M25x1,5 ; M18x1,5 ; M18x1,5L

*** auch für Stama-Magazine

*** Also for Stama loaders

Bar Feed Collets

Spannhülsen "Longlife" für Lademagazine
IEMCA, EDGE mit Aufschraubgewinde

Bar Feed Collets "Longlife" for Bar Feeders
IEMCA, EDGE with Right Hand Thread

Maximale Nutzung des Kanaldurchmessers
Maximum use of the channel diameter

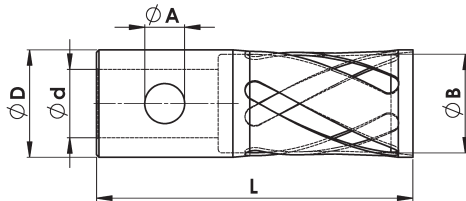

Ausführung L
Type L

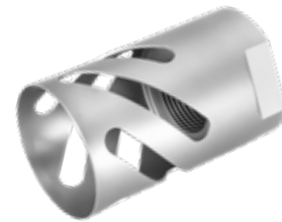

Vorteile der "Longlife"-Spannhülsen s. S. 12 - Advantages of "Longlife" bar feed collets see page 12

Bestell-Nr. order-no.	D	E-Nummer E-number	Bild picture	G	L	SW	B von from	B bis to
DI10L	10			M6x0,75	40	8	8,0	9,0
DI12L	12			M7x0,75	42	10	9,5	11,1
DI15L	15			M8x1	42	13	12,7	14,0
DI16L	16			M8x1	42	14	13,7	15,0
DI18L	18			M8x1	42	15	16,0	17,0
DI20L	20			M10x1	59	17	17,5	19,0
DI21L	21			M10x1	59	17		20,0
DI23L	23			M10x1	59	19	18,0	22,22
DI25L	25			M10x1	59	22	19,5	24,0
DI27L	27			M10x1	59	24	25,0	26,0
DI30L	30			M10x1	65	27	27,0	29,0
DI31L	31			M10x1	65	27	29,5	30,0
DI32L	32			M10x1	65	30	28,5	31,0
DI33L	33			M10x1	65	30	30,0	32,0
DI34L	34			M25x1,5	65	32		32,0
DI35L	35			M25x1,5	65	32	31,75	34,0
DI36L	36			M25x1,5	65	34		35,0
DI40L	40			M25x1,5	70	36	36,0	39,0
DI42L	42			M25x1,5	70	36	38,0	41,0
DI45L	45			M25x1,5	72	41	42,0	44,0
DI46L	46			M25x1,5	72	40	44,0	45,0
DI50L	50			M25x1,5	80	46	46,0	49,0
DI52L	52			M25x1,5	80	46		50,0
DI55L	55			M25x1,5	80	50	52,0	53,0
DI58L	58			M25x1,5	80	50	55,0	56,0
DI65L	65			M25x1,5	80	60	62,0	63,0
DI75L	75			M25x1,5	80	65	70,0	72,0

* Auch mit folgenden Gewinden lieferbar: M17x1 ; M25x1,5 ; M18x1,5 ; M18x1,5L
* Also available with threads:

** auch für Stama-Magazine

** Also for Stama loaders

18 Spannhülsen

Bar feed Collets

Spannhülsen für Lademagazine
J. CUCCHI mit Aufschraubgewinde

Bar Feed Collets for Bar Feeders
J. CUCCHI with Right Hand Thread

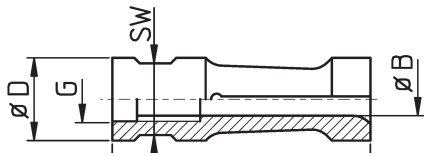

Bestell-Nr. order-no.	D	G	L	SW	B von from	B bis to
DC12	12	M7x0,75	52	10	3,0	11,0
DC14	14	M8x1	52	12	4,0	12,5
DC16	16	M8x1	52	14	4,0	15,0

Dünnwandige Spannhülsen auch als "Longlife" lieferbar

Thin-walled bar feed collets also available in "Longlife"-type

Spannhülsen für Lademagazine
Fedek / LNS Asia

Bar Feed Collets for Bar Feeders
Fedek / LNS Asia

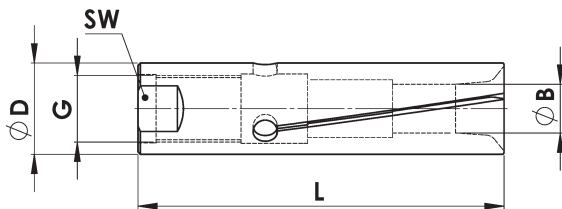

Bestell-Nr. order-no.	D	G	L	SW	B von from	B bis to
D10F675R	10	M6 x 0,75	42	8	1,5	9,0
D10F500L	10	M5 left	50	8	2,0	9,0
D10F508R	10	M5 x 0,8	50	8	2,0	9,0
D12F775R	12	M7 x 0,75	42	10	1,6	10,3
D12F500L	12	M5 left	45	10	1,6	10,3
D15F91L	15	M9 x 1 left	60	13	3,0	13,0
D15F101L	15	M10 x 1 left	60	13	3,0	13,0
D15F810R	15	M8 x 1	42	13	3,0	13,0
D15F101R	15	M10 x 1	60	13	3,0	13,0
D15F801R	15	M8 x 1	60	13	3,0	13,0
D16F810R	16	M8 x 1	42	14	10,0	14,25
D16F101L	16	M10 x 1 left	73	14	4,0	15,0
D16F91L	16	M9 x 1 left	58	14	10,0	14,25
D18F91L	18	M9 x 1 left	60	15	11,0	16,5
D18F101L	18	M10 x 1 left	59	15	11,0	16,5
D18F101R	18	M10 x 1	59	14	10,0	17,0

Bar Feed Collets

Spannhülsen für Lademagazine
IEMCA, EDGE, J. CUCCHI
mit Aufschraubgewinde

Bar Feed Collets for Bar Feeders
IEMCA, EDGE, J. CUCCHI
with Right Hand Thread

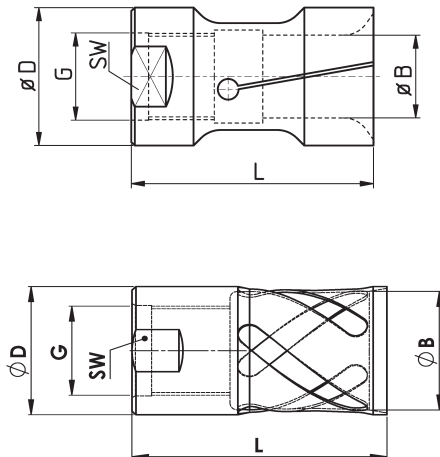

Ausführung L "Longlife"
Type L "Longlife"

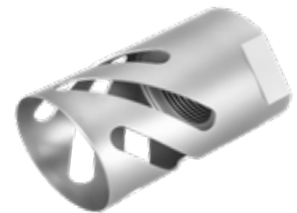

Vorteile der "Longlife"-Spannhülsen s. S. 12 - Advantages of "Longlife" bar feed collets see page 12

Maximale Nutzung des Kanaldurchmessers
Maximum use of the channel diameter

Bestell-Nr. order-no.	D	G	L	SW	B von from	B bis to
DIL29	29	M17x1	80	27	5,0	27,0
DIL30	30	M17x1	80	27	5,0	28,0
DIL32	32	M25x1,5	80	30	5,0	29,0
DIL32L*	32	M25x1,5	80	30		30,0
DIL34	34	M25x1,5	80	30	20,0	32,0
DIL34L*	34	M25x1,5	80	30	31,75	32,0
DIL36	36	M25x1,5	80	30	20,0	34,0
DIL38	38	M25x1,5	80	36	20,0	35,0
DIL40	40	M25x1,5	80	36	10,0	37,0
DIL40L*	40	M25x1,5	80	36		38,0
DIL42	42	M25x1,5	80	36	10,0	40,0
DIL44	44	M25x1,5	80	41	38,0	42,0
DIL46	46	M25x1,5	80	41	39,0	44,0
DIL46L*	46	M25x1,5	80	41		44,0
DIL48	48	M25x1,5	80	46	40,0	46,0
DIL48L*	48	M25x1,5	80	46		46,0

*Ausführung "Longlife"

*Type "Longlife"

Bar feed Collets

Spannhülsen für Lademagazine
P. CUCCHI mit Aufschraubgewinde links

Bar Feed Collets for Bar Feeders
P. CUCCHI with Left Hand Thread

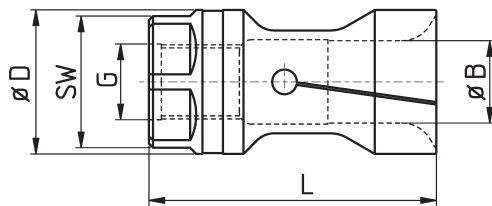

Bestell-Nr. order-no.	Magazin magazine	D	G	L	SW	B von from	B bis to
DX19	CUCCHI PB20	19	M10x1 L	60	17	4,0	17,0
DX20	CUCCHI PB20	20	M10x1 L	60	17	11,5	18,0
DX23	CUCCHI PB23	23	M14x1 L	60	21	4,0	21,0
DX24	CUCCHI PB24	24	M14x1 L	60	22	21,7	22,0
DX25	CUCCHI PB24	25	M14x1 L	60	22	6,0	22,0
DX29	CUCCHI PB30	29	M18x1,5 L	65	27	5,0	27,5
DX30	CUCCHI PB30	30	M18x1,5 L	65	28	16,5	28,0
DX32	CUCCHI PB32	32	M18x1,5 L	65	28	20,0	29,0
DX33	CUCCHI PB35A	33	M18x1,5 L	70	30	11,5	30,0
DX34	CUCCHI PB35A	34	M18x1,5 L	70	32	11,0	32,0
DX35	CUCCHI PB35	35	M18x1,5 L	70	32	21,0	33,0
DX37	CUCCHI PB38	37	M25x1,5 L	70	34	10,0	36,0
DX39	CUCCHI PB38	39	M25x1,5 L	70	36	16,0	36,0
DX40	CUCCHI PB42	39,8	M25x1,5 L	70	36	24,0	37,0
DX41	CUCCHI PB42	41	M25x1,5 L	70	36	19,0	39,0
DX44	CUCCHI PB42	44	M25x1,5 L	70	36	40,0	42,0
DX47	CUCCHI PB48	47	M30x1,5 L	70	40	12,0	45,0
DX50	CUCCHI PB	49,7	M30x1,5 L	70	46	20,0	47,0
DX55	CUCCHI PB	55	M30x1,5 L	80	50	35,0	52,0
DX60	CUCCHI PB60	59,7	M30x1,5 L	80	55	19,0	57,0
DX65	CUCCHI PB68	65	M30x1,5 L	80	60	50,0	62,0
DX70	CUCCHI PB70-72	69,5	M30x1,5 L	80	Nut	60,0	65,0
DX75	CUCCHI PB75	75	M30x1,5 L	80	Nut	65,0	70,0
DX88	CUCCHI PB90	88	Bohrung / bore 40	110	--	60,0	82,2
DV34		34	M25x1,5 L	70	30	20,0	30,0
DV34L		34	M25x1,5 L	70	30	31,75	32,0

Bar Feed Collets

Spannhülsen "Longlife" für Lademagazine
P. CUCCHI mit Aufschraubgewinde links

Bar Feed Collets "Longlife" for Bar Feeders
P. CUCCHI with Left Hand Thread

Maximale Nutzung des Kanaldurchmessers
Maximum use of the channel diameter

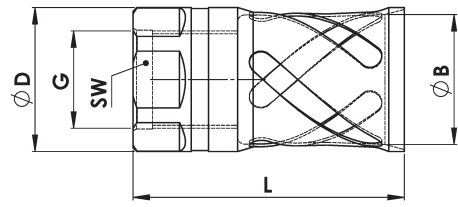

Vorteile der "Longlife"-Spannhülsen s. S. 12 - Advantages of "Longlife" bar feed collets see page 12

Bestell-Nr. order-no.	Magazin magazine	D	G	L	SW	B von from	B bis to
DX19L	CUCCHI PB20	19	M10x1 L	60	17	17,0	17,2
DX20L	CUCCHI PB20	20	M10x1 L	60	17	18,0	19,0
DX23L	CUCCHI PB23	23	M14x1 L	60	21	19,4	22,0
DX29L	CUCCHI PB30	29	M18x1,5 L	65	27		27,5
DX30L	CUCCHI PB30	30	M18x1,5 L	65	28	27,5	28,0
DX32L	CUCCHI PB32	32	M18x1,5 L	65	28		30,0
DX34L	CUCCHI PB35A	34	M18x1,5 L	70	32	27,6	32,5
DX35L	CUCCHI PB35	35	M18x1,5 L	70	32	32,0	33,0
DX37L	CUCCHI PB38	37	M25x1,5 L	70	34	32,0	35,0
DX40L	CUCCHI PB42	39,8	M25x1,5 L	70	36	35,0	38,0
DX41L	CUCCHI PB42	41	M25x1,5 L	70	36	35,0	40,0
DX42L	CUCCHI PB42	42	M25x1,5 L	70	36		40,0
DX47L	CUCCHI PB48	47	M30x1,5 L	70	40	44,0	45,0
DX50L	CUCCHI PB	49,7	M30x1,5 L	70	46	41,2	48,0
DX60L	CUCCHI PB60	59,7	M30x1,5 L	80	55		58,0

22 Spannhülsen

Bar feed Collets

Spannhülsen für Lademagazine CAV

Bar Feed Collets for Bar Feeders CAV



Bild 1



Bild 2

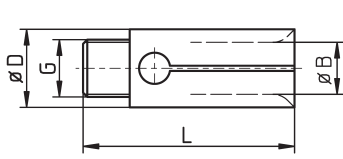

Bild 3

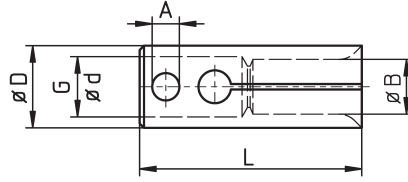

Bild 4: Ausführung L "Longlife" version

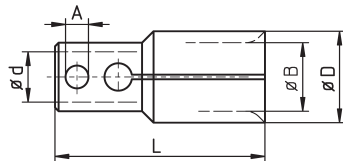

Bestell-Nr. order-no.	D	G / d	L	A	B von from	B bis to	pic	Magazine magazines
CAV 07	7	M6 x 1 L	40	--	1,0	5,56	1	CAV16/20L-IS
CAV07L	7	M6 x 1 L	40	--	5,5	5,95	4	
					1/16", 5/64", 3/32", 7/64", 1/8", 9/64", 5/32", 11/64", 3/16", 13/64", 7/32"			
					15/64"			
CAV 10	10	M6 x 1 L	40	--	1,98	8,73	1	CAV12M-IS
CAV 12	12	M6 x 1 L	40	--	7,93	10,5	1	
CAV12L	12	M6 x 1 L	40	--	10,5	11,11	4	
					5/64", 3/32", 7/64", 1/8", 9/64", 5/32", 11/64", 3/16", 13/64", 7/32", 1/4", 9/32", 5/16", 11/32"			
					5/16", 11/32", 3/8", 13/32"			
					7/16"			
CAV 15	15	10	55	6	3	12,7	2	CAV16/20L-IS
CAV15L	15	10	55	6	12,7	13,49	4	
CAV 17	17	10	55	6	11,11	15,87	2	
					1/8", 9/64", 5/32", 11/64", 3/16", 13/64", 7/32", 1/4", 9/32", 5/16", 11/32", 3/8", 13/32", 7/16", 15/32", 1/2"			
					17/32"			
					7/16", 15/32", 1/2", 17/32", 9/16", 19/32", 5/8"			
CAV 19	19	10	56,5	6	12,7	17,46	2	CAV20L-IS
CAV 21	21,1	10	56,5	6	12,7	19,84	2	
					1/2", 17/32", 9/16", 19/32", 5/8", 21/32", 11/16"			
					1/2", 17/32", 9/16", 19/32", 5/8", 21/32", 11/16", 23/32", 3/4", 25/32"			
CAV 25	25	16	76	8	5	22	3	
CAV 32	32	16	76	8	15,5	29	3	
CAV 34	34	16	76	8	19	31	3	

Bar Feed Collets

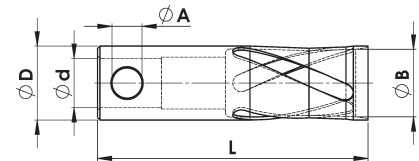
Spannhülsen mit Innenprofil 4-kant und 6-kant

Bar Feed Collets with Inner Profile Square and Hexagonal



Alle Standardspannhülsen auch mit Innenprofilierung erhältlich. Äußere Maße identisch mit den Rundausführungen. Vorteile bei 4- / 6-kant-Material: Stärkere Klemmwirkung, absolut verdrehsicher

All standard types of bar feed collets are available with inner profile. Outside dimensions are identical with round types. Advantages for sq / hex material: Stronger clamping, absolutely lock of distortion

Typ type	Magazine magazines	Seite page
D	FMB, IEMCA, LNS, TRAUB, TORNOS	7
TD	FMB, BREUNING IRCO, LNS, TORNOS	10
DI	IEMCA	12
DX	P. CUCCHI	15
DT	TOP Automazioni	24

Bei Bestellungen einfach "square" bzw. "hex" hinter die Bestellnummer

When ordering simply "square" or "hex" after the order number

Beispiele: - examples: DX28 26,5 square 4-kt / sq
DX42 39,0 hex 6-kt / hex

24 Spannhülsen

Bar feed Collets

Spannhülsen für Lademagazine
TOP Automazioni

Bar Feed Collets for Bar Feeders
TOP Automazioni

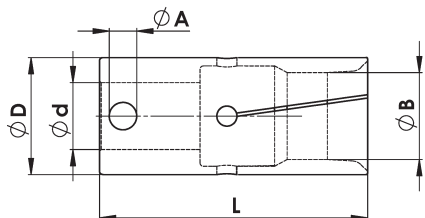

Bestell-Nr. order-no.	D	d	L	A	B von from	B bis to
DTOP20	20	14	80	5	5	17,5
DTOP25	25	14	80	5	15	22
DTOP30	30	20	80	8	20	28
DTOP32	32	20	80	8	22	29
DTOP35	35	20	80	8	25	32
DTOP40	40	20	80	8	30	38
DTOP42	42	20	80	8	32	40
DTOP45	45	20	80	8	35	42
DTOP50	50	20	80	8	40	47
DTOP52	52	20	80	8	40	49
DTOP55	55	20	80	8	45	52
DTOP60	60	20	80	8	50	57

Auch Zollmaße erhältlich

Inch sizes also available

Spannhülsen "Longlife" für Lademagazine
TOP Automazioni

Bar Feed Collets "Longlife" for Bar Feeders
TOP Automazioni

Maximale Nutzung des Kanaldurchmessers
Maximum use of the channel diameter

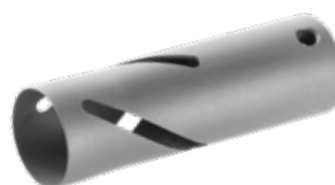
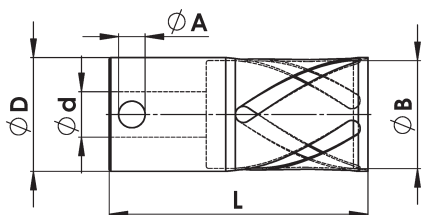

Vorteile der "Longlife"-Spannhülsen s. S. 12 - Advantages of "Longlife" bar feed collets see page 12

Bestell-Nr. order-no.	D	d	L	A	B von from	B bis to
DTOP20L	20	14	80	5	17	19
DTOP25L	25	14	80	5	22	24
DTOP30L	30	20	80	8	27	29
DTOP32L	32	20	80	8	28	31
DTOP35L	35	20	80	8	32	34
DTOP40L	40	20	80	8	37	39
DTOP42L	42	20	80	8	37	41
DTOP45L	45	20	80	8	42	44
DTOP50L	50	20	80	8	47	49
DTOP52L	52	20	80	8	47	51
DTOP55L	55	20	80	8	52	54
DTOP60L	60	20	80	8	57	59

Bar Feed Collets

Adapter für Spannhülsen DTOP
TOP AutomazioniAdapter for Bar Feed Collets DTOP
TOP Automazioni

Bestell-Nr. order-no.	d1	D	A1	L	d2	A2
DTOP-ADP-TOP1414	14	20	5	91	14	5
DTOP-ADP-TOP2014	20	30	8	91	14	5
DTOP-ADP-TOP2020		30	8	91	20	8
DTOP-ADP-TOP2514	25	35	8	91	14	8
DTOP-ADP-TOP2520		35	8	91	20	8
DTOP-ADP-TOP3014	30	50	8	91	14	8
DTOP-ADP-TOP3020		50	8	91	20	8
DTOP-ADP-TOP3030		50	8	91	30	8

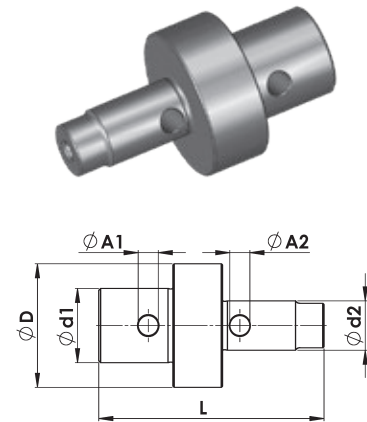
Adapter für Spannhülsen D
TOP AutomazioniAdapter for Bar Feed Collets D
TOP Automazioni

Bestell-Nr. order-no.	d1	D	A1	L	d2	A2
DTOP-ADP-14D07	14	20	5	114	7	4
DTOP-ADP-14D08			5	114	8	4
DTOP-ADP-14D11			5	115,5	11	6
DTOP-ADP-14D14			5	102,5	14	8
DTOP-ADP-20D07	20	30	8	114	7	4
DTOP-ADP-20D08			8	114	8	4
DTOP-ADP-20D11			8	115,5	11	6
DTOP-ADP-20D14			8	102,5	14	8
DTOP-ADP-20D20	25	35	8	105	20	8
DTOP-ADP-25D07			8	114	7	4
DTOP-ADP-25D08			8	114	8	4
DTOP-ADP-25D11			8	115,5	11	6
DTOP-ADP-25D14	30	50	8	102,5	14	8
DTOP-ADP-25D20			8	105	20	8
DTOP-ADP-30D07			8	114	7	4
DTOP-ADP-30D08			8	114	8	4
DTOP-ADP-30D11	30	50	8	115,5	11	6
DTOP-ADP-30D14			8	102,5	14	8
DTOP-ADP-30D20			8	105	20	8

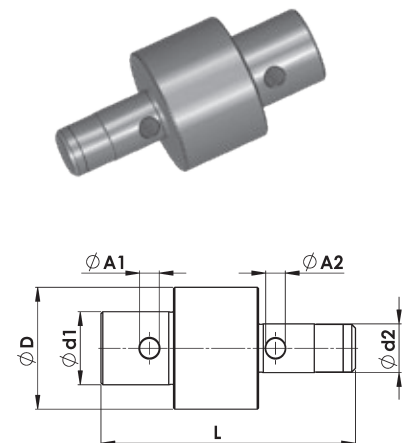

26 Spannhülsen

Bar feed Collets

Adapter für Spannhülsen TD TOP Automazioni

Adapter for Bar Feed Collets TD TOP Automazioni

Bestell-Nr. order-no.	d1	D	A1	L	d2
DTOP-ADP-20TD20	20	30	8	70	20
DTOP-ADP-25TD20	25	35	8	70	20
DTOP-ADP-30TD20	30	50	8	70	20

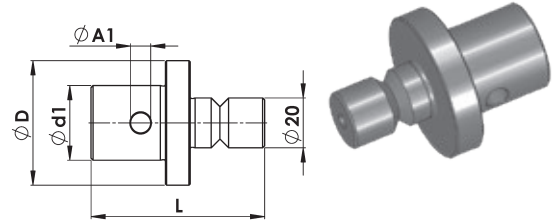

Einsatz der Spannhülsenadapter

Use of the Adapters

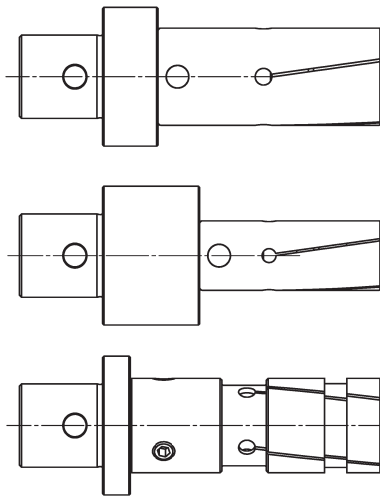

Original-Adapter mit DTOP-Spannhülsen
Original adapters with DTOP-Bar Feed Collets

D-Adapter mit D-Spannhülsen
D-adapters with D-type Bar Feed Collets

TD-Adapter mit TD-Spannhülsen
TD-adapters with TD-type Bar Feed Collets

Beim Einsatz unterschiedlicher Spannhülsen mit den jeweiligen Adaptern, ergibt sich im Lader immer dieselbe Position der Spannhülsen vorderkante

When using different bar feed collets with the respective adapters, the same position of the collet front edge always results in the loader

Querstifte für Spannhülsenlagerungen u. Spannhülsenadapter

Cross pins for revolving ends and adapters

Für Lagerungen mit Querstift for revolving ends with cross pin		
Best.-Nr. order-no.	d	L
Q D10	4	10
Q D12	4	11,8
Q D15	6	14,8
Q D16	6	15,6
Q D18	6	17,8
Q D20	8	19,8
Q D22	8	21,8
Q D24	8	23,8
Q D25	8	24,8
Q D28	8	27,8
Q D30	8	29,6
Q D32	8	31,6
Q D36	8	35,6

Für Adapter + Spannhülsen "DTOP" for adapter + bar feed collets "DTOP"		
Best.-Nr. order-no.	d	L
Q TOP19	5	19
Q TOP24	5	24
Q TOP30	8	30
Q TOP40	8	40
Q TOP45	8	45
Q TOP60	8	60

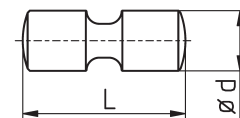

Bar Feed Collets

Zentrierhülsen f. Lademagazine FMB, IEMCA, LNS, TRAUB, TORNOS

Bestell-Nr. order-no.	D	d	L
D10K	10	7	40
D12K	12	8	40
D13K	13	8	40
D15K	15	11	40
D16K	16	11	40
D18K	18	11	40
D20K	20	14	65
D22K	22	14	65
D25K	25	20	65
D28K	28	20	65
D30K	30	20	65
D32K	32	20	65
D36K	36	20	65

Materialausstoß nach vorn - for front ejection

Bar Feed Cone Collets for Bar Feeders FMB, IEMCA, LNS, TRAUB, TORNOS

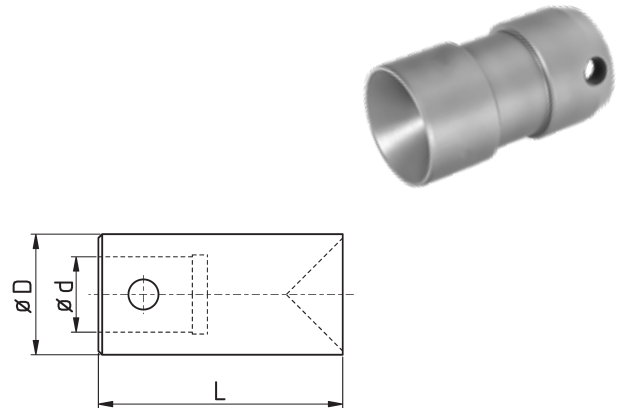

Zentrierhülsen f. Lademagazine FMB, IRCO, LNS, TORNOS

Bestell-Nr. order-no.	D	d	L
TD25K	25	20	90
TD30K	30	20	90
TD32K	32	20	90
TD34K	34	20	90
TD36K	36	20	90
TD40K	40	20	90
TD42K	42	20	90
TD45K	45	20	90
TD50K	50	20	90
TD60K	60	20	90
TD65K	65	20	90
TD67K	67	20	90

Materialausstoß nach vorn - for front ejection

Bar Feed Cone Collets for Bar Feeders FMB, IRCO, LNS, TORNOS

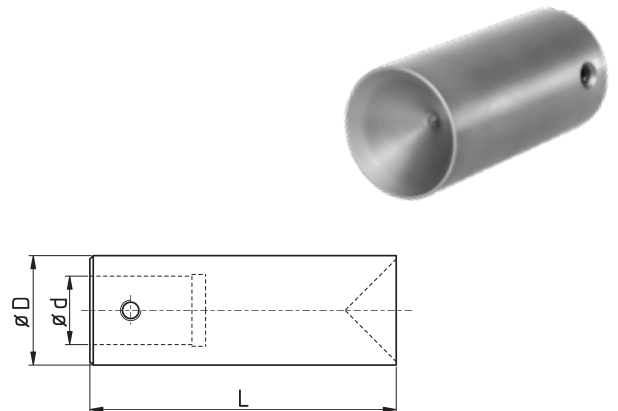

Zentrierhülsen f. Lademagazine IEMCA

Bestell-Nr. order-no.	D	G	L
DI20K	20	M10 x 1	59
DI25K	25	M10 x 1	59

Materialausstoß nach vorn - for front ejection

Bar Feed Cone Collets for Bar Feeders IEMCA

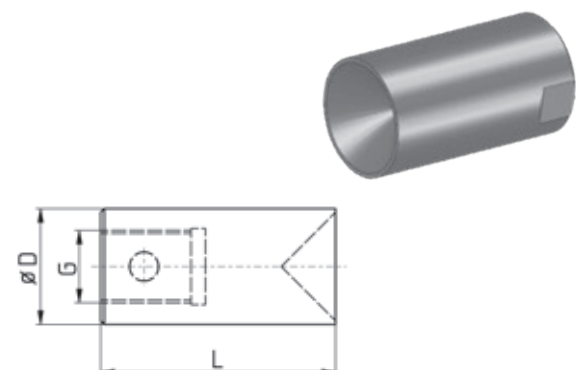

Bar feed Collets

Spanndorne / Innenspannhülsen für Rohre
FMB, IEMCA, LNS, TRAUB, TORNOS

Bar Feed Collets for Internal Gripping
FMB, IEMCA, LNS, TRAUB, TORNOS

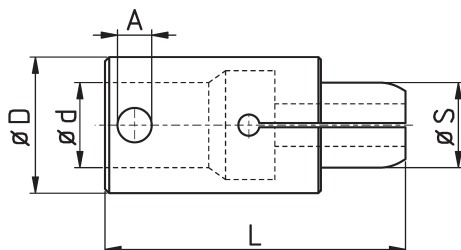

Bestell-Nr. order-no.	D	G / d	A	L	S von from	S bis to
D07SP	07	M5	--	37	5,0	6,0
D10SP	10	7	4	40	6,0	9,0
D12SP	12	8	4	40	5,0	11,0
D13SP	13	8	4	40	8,0	12,7
D15SP	15	11	6	40	4,0	14,0
D16SP	16	11	6	40	6,3	15,0
D18SP	18	11	6	40	5,0	17,0
D20SP	20	14	8	65	5,0	19,0
D22SP	22	14	8	65	15,0	21,0
D25SP	25	20	8	65	6,0	24,0
D28SP	28	20	8	65	8,0	27,0
D30SP	30	20	8	65	15,0	29,0
D32SP	32	20	8	65	10,0	31,0
D36SP	36	20	8	65	8,0	35,0
D40SP	40	20	8	65	20,0	29,0
D42SP	42	20	8	65	20,0	41,0

Spanndorne / Innenspannhülsen für Rohre
IEMCA (DI) und P.CUCCHI (DX)

Bar Feed Collets for Internal Gripping
IEMCA (DI) and P. CUCCHI (DX)



Ausführung DI
Type DI



Ausführung DX
Type DX

Alle "DI"- und "DX"- Spannhülsen auch als Spanndorne erhältlich, vgl. S. 16 + 20

All "DI" and "DX" bar feed collets also available as bar feed collets for internal gripping, see page 16 + 20

Viele Maße auf Lager, bitte fragen Sie an

many sizes available in stock, please request

Best.Nr.: DI . . SP bzw. DX . . SP
order-no.: resp.

Bar Feed Collets

Spanndorne / Innenspannhülsen für Rohre
"Turbo" für FMB, BREUNING IRCO, LNS, TORNOS

Bar Feed Collets for Internal Gripping
"Turbo" for FMB, BREUNING IRCO, LNS, TORNOS

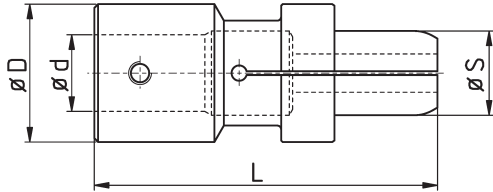

Bestell-Nr. order-no.	D	d	L	Gew	S von from	S bis to
TD25SP	25	20	90	M5	5,0	24,0
TD30SP	30	20	90	M6	8,0	29,0
TD32SP	32	20	90	M6	8,0	31,0
TD34SP	34	20	90	M6	10,0	33,0
TD36SP	36	20	90	M8	9,0	35,0
TD38SP	38	20	90	M8	12,0	37,0
TD40SP	40	20	90	M8	15,0	39,0
TD42SP	42	20	90	M8	14,0	41,0
TD45SP	45	20	90	M8	17,0	44,0
TD50SP	50	20	90	M8	17,0	49,0
TD60SP	60	20	90	M8	24,0	59,0
TD65SP	65	20	90	M8	40,0	64,0

Bar feed Collets

Spanndorne / Innenspannhülsen für Rohre
INDEX MS

Bar Feed Collets for Internal Gripping
INDEX MS

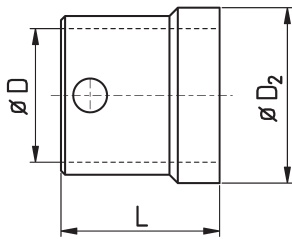

Anschlag - stopper

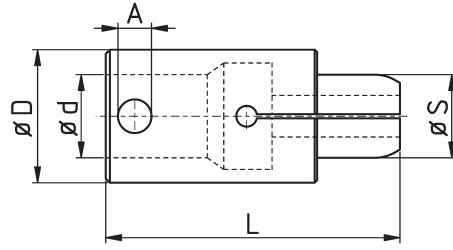

Spannhülse - collet



Bestell-Nr. order-no.		Index Orig. Nr.	Schieber feeder	D / D ₂ **	S	A	d	L	Maschine
D104522 8.0 SP	Spannhülse <i>collet</i>	927434.1232	12	10,3	8	4	8	45	MS22 / MS40
ASD104522-**	Anschlag <i>sleeve</i>	927435.**31		13,0 - 23,0		4		32	
D104532 8.0 SP	Spannhülse <i>collet</i>	927535.1231	12	10,3	8	4	8	45	MS32
ASD104532-**	Anschlag <i>sleeve</i>	927536.**31		13,0 - 18,0		4		32	
D104640 8.0 SP	Spannhülse <i>collet</i>	927434.1233	12	10,3	8	4	8	46	MS22 / MS32 / MS40
ASD104640-**	Anschlag <i>sleeve</i>	927435.**32		13,0 - 23,0		4		26	
D164522 15.0 SP	Spannhülse <i>collet</i>	927535.1831	18	16	15	6	11	45	MS22 / MS32 / MS40
ASD164522-**	Anschlag <i>sleeve</i>	927536.**31		19,0 - 25,0		6		32	
D164632 15.0 SP	Spannhülse <i>collet</i>	927535.1841	18	16	15	6	11	46,5	MS22 / MS32 / MS40
ASD164632-**	Anschlag <i>sleeve</i>	927536.**41		19,0 - 25,0		6		26,5	
D184552 15.0 SP	Spannhülse <i>collet</i>	927934.1832	18	18	15	6	11	45	MS52
ASD184552-**	Anschlag <i>sleeve</i>	927975.**31		22,0 - 32,0				20	
D197040 15.0 SP	Spannhülse <i>collet</i>	927434.2332	23	19	15	8	14	70	MS40
ASD197040-**	Anschlag <i>sleeve</i>	927435.**31		24,0 - 32,0		8		52	
D196640 15.0 SP	Spannhülse <i>collet</i>	927434.2333	23	19	15	8	14	66,5	MS40
ASD196640-**	Anschlag <i>sleeve</i>	927435.**32		24,0 - 32,0				46,5	
D226632 15.0 SP	Spannhülse <i>collet</i>	927535.2531	25	22	15	8	15	66	MS32
ASD226632-**	Anschlag <i>sleeve</i>	927536.**31		26,0 - 36,0				46,5	
D277040 15.0 SP	Spannhülse <i>collet</i>	927434.3232	32	27	15	8	20	70	MS40
ASD277040-**	Anschlag <i>sleeve</i>	927435.**31		33,0 - 40,0		8		52	
D276140 15.0 SP	Spannhülse <i>collet</i>	927434.3233	32	27	15	8	20	61	MS40
ASD276140-**	Anschlag <i>sleeve</i>	927435.**32		33,0 - 40,0				41	
D327052 20.0 SP	Spannhülse <i>collet</i>	927934.3232	32	32	20	8	20	70	MS52
ASD327052-**	Anschlag <i>sleeve</i>	927975.**31		33,0 - 42,0				38	
D427052 20.0 SP	Spannhülse <i>collet</i>	927934.4232	42	42	20	8	20	70	MS52
ASD427052-**	Anschlag <i>sleeve</i>	927975.**31		43,0 - 52,0				38	
D1845IMS52 15.0 SP	Spannhülse <i>collet</i>		18	18	15	6	11	45	
D3270IMS52 20.0 SP	Spannhülse <i>collet</i>		32	32	20	8	20	70	
D4270IMS52 20.0 SP	Spannhülse <i>collet</i>		42	42	20	8	20	70	

Bar Feed Collets

Spannhülsen "Longlife" vulkanisiert

Bar Feed Collets "Longlife" vulcanized



Alle "Longlife"-Stahlausführungen auch vulkanisiert lieferbar

All "Longlife"-steel-types also available vulcanized

Vorteile:	advantages:
1. Lieferbar für alle Lademagazine	1. Available for all types of magazine bar loaders
2. Lange Lebensdauer bei angefasten Stangen	2. Longer life (with chamfered bars)
3. Sehr gute Geräusch- und Schwingungsdämpfung	3. Excellent noise and vibration damping
4. Hohe Auszugskräfte	4. High pull out strength
5. Auch für 6-kt Material einsetzbar	5. Also usable for hexagonal material
6. Kein Auslaufen des Kühlschmierstoffes mehr	6. No more problems with loss of coolant
7. Nur geringes Aufmaß auf den Nenndurchmesser	7. Only small oversize to the nominal diameter

Bei Bestellungen einfach "V" hinter die Bestell-Nr.

When ordering simply "V" after the order number

Beispiele: - examples:

D26L 24,5 V
TD45L 43,0 V

DX39L 37,5 V

Spanndorne / Innenspannhülsen vulkanisiert

Bar Feed Collets for Internal Gripping vulcanized



Alle Spanndorn-Stahlausführungen auch vulkanisiert lieferbar

All steel-type bar feed collets for internal gripping also available vulcanized

Vorteile:	advantages:
1. Lieferbar für alle Lademagazine	1. Available for all types of magazine bar loaders
2. Sehr gute Geräusch- und Schwingungsdämpfung	2. Excellent noise and vibration damping
3. Hohe Auszugskräfte	3. High pull out strength
4. Kein Auslaufen des Kühlschmierstoffes mehr	4. No more problems with loss of coolant
5. Kein Aufmaß auf den Nenndurchmesser	5. No oversize to the nominal diameter

Bei Bestellungen einfach "V" hinter die Bestell-Nr.

When ordering simply "V" after the order number

Beispiele: - examples:

D26SP 20,0 V
TD45SP 35,0 V

DX39SP 16,0 V

Bar feed Collets

Gummi Spannhülsen und Spanndorne (Rohlinge)

Rubber-Fix Bar Feed Collets and Collets for Internal Gripping (Blank)



Besonders geeignet für Entlademagazine - *Especially suitable for unloading systems*

Vorteile:	advantages:
1. Sehr gute Geräusch- und Schwingungsdämpfung	1. <i>Excellent noise and vibration damping</i>
2. Hohe Auszugskräfte	2. <i>High pull out strength</i>
3. Auch für 6-kt Material einsetzbar	3. <i>Also useable for hexagonal material</i>
4. Kein Auslaufen des Kühlschmierstoffes mehr	4. <i>No more problems with loss of coolant</i>
5. Großer Spannbereich - ca. 0,5 mm	5. <i>Larger clamping range, about 0,5 mm</i>
6. Kein ungewolltes Öffnen von Spannsegmenten durch Zentrifugalkräfte	6. <i>No loss of gripping power with high centrifugal forces</i>
7. Auch als Notfall-Spannhülsen / Spanndorne (beliebiges Abdrehen oder Aufbohren auf Wunschmaß)	7. <i>Also available as emergency version for sizing by customer</i>
8. Kein Zerkratzen empfindlicher Oberflächen (Schmuck- + Medizintechnik)	8. No scratching of sensitive surfaces (jewelry + medical industry)

Gummi-Spannhülsen

Rubber-Fix Bar Feed Collets

Maße wie Stahlausführungen
Same dimensions as steel-types

D Bestell-Nr. order-no.	TD Bestell-Nr. order-no.	DI Bestell-Nr. order-no.	DX Bestell-Nr. order-no.
D07G	TD25G	DI12G	DX19G
D10G	TD30G	DI15G	DX20G
D12G	TD32G	DI16G	
D15G	TD36G	DI20G	
D16G	TD38G	DI25G	
D18G	TD40G	DI30G	
D20G	TD42G	DI32G	
D22G	TD45G	DI42G	
D23G	TD50G		
D25G	TD60G		
D28G	TD65G		
D30G			
D32G			
D35G			
D36G			
D42G			

Weitere Abmessungen auf Anfrage
Aufgebohrt / abgedreht auf Maß: Preis wie Standardhülsen
Best.-Nr. mit Nennmaß ergänzen - z.B. TD32G 10,0

Gummi-Spanndorne

Rubber-Fix Bar Feed Collets for Internal Gripping

Maße wie Stahlausführungen
Same dimensions as steel-types

D Bestell-Nr. order-no.	TD Bestell-Nr. order-no.	DI Bestell-Nr. order-no.	DX Bestell-Nr. order-no.
D10SPG	TD25SPG	DI12SPG	
D12SPG	TD30SPG	DI15SPG	
D15SPG	TD32SPG	DI16SPG	
D16SPG	TD36SPG	DI20SPG	
D20SPG	TD42SPG	DI22SPG	
D22SPG	TD50SPG	DI25SPG	
D25SPG		DI32SPG	
D32SPG		DI40SPG	
D35SPG			
D36SPG			
D42SPG			

Other dimensions on request
Rebored / turned on measure: price like standard version
When ordering simply the nominal size after the Order number - e.g. TD32G 10,0